

## SPRAY TURBINES TO INCREASE RAIN BY ENHANCED EVAPORATION FROM THE SEA

**Stephen Salter**

Division of Engineering, University of Edinburgh  
Mayfield Road, Edinburgh EH9 3JL, Scotland  
S.Salter@ed.ac.uk

### ABSTRACT

It seems that one of the effects of global warming is to increase rainfall in some parts of the world while reducing it in others. With the growth in demand for water the effects of any reduction on political stability and human happiness are profound. Several regions in the Mediterranean are vulnerable.

The amounts of energy involved in weather systems are so very large that it is difficult for engineers to influence them. However the evaporation of water from the sea surface is slow and inefficient because of the need for large amounts of latent heat and because the perpendicular component of turbulence in the air vanishes at the surface leaving a stagnant humid layer (Csanady 2001). The wind has to blow over thousands of kilometres of warm sea before it can bring rain. Saudi Arabia is dry because the Red Sea and the Persian Gulf are narrow. Chile is dry because the Humboldt current is cold.

Calculations show that some remediation may be possible using a mechanism that can be controlled to suit local needs. This paper describes the design of a floating, vertical-axis wind turbine which pumps sea water through the humid stagnant layer and sprays it in fine droplets with a large increase in surface area. The spray release height is chosen to give time for a large fraction of the water to evaporate when mixed with air in the turbine wake. The distance from land is chosen so that residual very salty drops fall into the sea. The humidified air is likely to produce rain when it reaches rising ground. The technique allows evaporation from narrow stretches of sea with winds blowing over the fetches associated with daily sea breezes caused by rising air ashore. Narrow waters can be made to behave like much wider oceans with seasonal prevailing winds but control remains in the hands of the turbine owners.

### PREVIOUS RAIN-MAKING METHODS

Surface tension forces on very small drops make them become unstable and collapse. Even when the air is super-saturated with water vapour it is still necessary for there to be nucleation particles of the right size and chemical nature before rainfall can be triggered. Most of the attempts at rain-making have employed aircraft to seed supersaturated clouds with substances such as silver iodide or solid carbon dioxide. Very small quantities of the seeding substance are needed so that the aircraft operation costs more than the silver.

Seeding has a sound scientific basis but it is difficult to do repeatable demonstrations. It works only with super-saturated air. It certainly generates extreme hostility from people down wind who will believe, with good reason, that their rain has been stolen. Furthermore once an event with the energy of a heavily super-saturated cloud has been triggered, the rain may come in uncomfortably large amounts, leading to flash floods. In the desert more people die by drowning than from thirst.

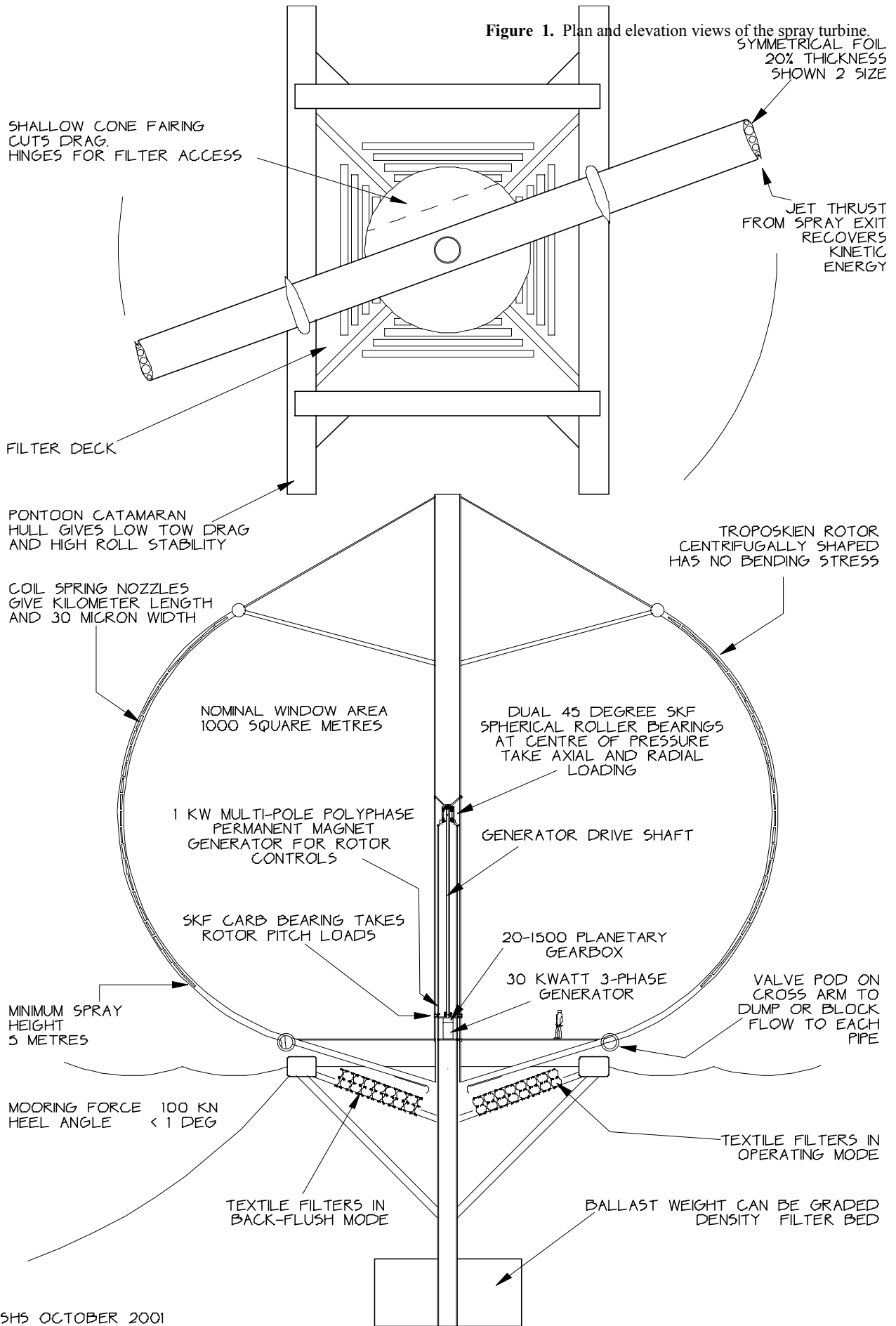
### TURBINE DESIGN

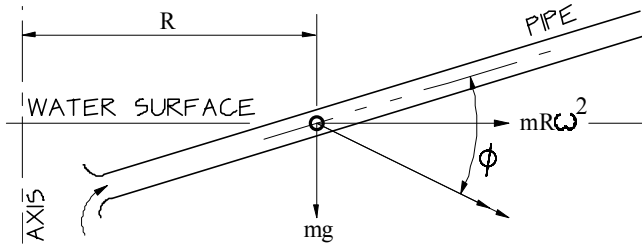
The horizontal axis wind turbine has decisively beaten the vertical axis configuration for electricity generation. The differences are interesting. In a constant wind speed, horizontal axis machines have moderately steady aerodynamic loading but reversing gravitational loads, while vertical axis ones have reversing aerodynamic loads and constant gravitational ones. Horizontal axis blades can have the more efficient asymmetrical foil sections while vertical axis ones have to be symmetric. The vertical axis blades go through an idle point twice each rotation and experience a wide variation in the angle of incidence of airflow, while horizontal axis blades can use chord variation and blade twist to stay closer to ideal values. This gives them an advantage in efficiency that outweighs the cost of a tower and the difficulty of having power conversion plant far above ground. It would be possible to use a horizontal axis machine for spray generation but a boost pump would be needed to lift water to hub height. If the amount of water in the blades were ever different, there would be serious balance problems so that there would have to have reliable flow control between blades.

The central part of the proposed vertical-axis spray turbine rotor has an approximation to the shape of the troposkien (Reis 1975) as shown in figure 1. This is the shape adopted by a flexible spinning body like a skipping-rope. It allows all forces to be taken as pure tensions rather than bending moments. A spray turbine would have a larger ratio of diameter to height than a land-based electricity-generating one because it is not necessary to release water from a very great height and we are concerned about stability in heel. Faired cross arms join the blades to the central shaft. The blades are hollow and will be filled with water pipes.

For spray generation the vertical axis configuration has the overwhelming advantage that it provides an extremely efficient pump with no moving parts, almost free. This is shown in figure 2. The lower part of the blade breaks through the water surface close to the axis at a shallow slope. The angle of this slope is critical to the operation of the pumping action. Consider the forces on an element of water in the pipe at the water surface. It will feel the force of gravity vertically downwards and also a centrifugal force horizontally outwards. If the resultant of these two forces makes an angle less than 90 degrees to the line of the blade in the direction away from the axis then water will tend to move outwards. As the radius increases so will centrifugal forces and so the slope can increase. It is desirable that the rapidly moving parts of the blades are above wave height. This mechanism can easily produce a pressure of 10 bar, far more than is needed to lift water to the release height. The pump has no accurate machined parts, pistons, valves or sliding seals.

Figure 1. Plan and elevation views of the spray turbine.





**Figure 2.** A side view of the sloped pipe which performs centrifugal pumping. The resultant force on water at the surface will be outwards if  $\phi < 90$  degrees.

### Drop size

Water will be released from the trailing edges of the blades as a fine spray from heights between 5 and 20 metres into the turbulent wake of the rotor. The diameter of the spray drops has two important effects. Firstly it sets the surface area available for evaporation. The area of a volume  $Q$  split into drops of diameter  $d$  is  $6Q/d$  so a one-metre cube of water at the sea surface would have its surface area increased by 200,000 times if it were split into 30 micron drops. Secondly the diameter sets the rate of fall according to Stokes law, with gravity and drag in balance. For drop diameter  $d$  of density  $\rho$  (about 1020 kg/m<sup>3</sup>) falling under gravity  $g$  in air of dynamic viscosity  $\mu$  (about 18  $\mu$ Pa s) the velocity is given by Eq. (1)

$$V = \frac{\rho g d^2}{18\mu} \quad (1)$$

This predicts that our 30 micron drop would initially fall at only 28 mm per second. With no evaporation, the centre of a plume of drops would take a little over 6 minutes to fall 10 metres into the sea having travelled 2.9 kilometres. We can call the product of surface area and time the 'evaporation opportunity'. The available surface area rises with the inverse of diameter, while fall time rises with the inverse square. This means that evaporation opportunity rises with the inverse cube of diameter, which makes drop size a very powerful control parameter.

The average salinity of sea water is about 3.5% by weight but the salinity of brine cannot exceed 35%, at which point salt crystals form. Crystallisation produces a crust on the surface of the drop that effectively prevents all further evaporation. This means that we can never evaporate more than 90% of the water we have sprayed. At crust formation the diameter will be about 0.464 of the starting diameter and be falling at less than a quarter of the velocity. It is important that the majority of these residual salt fragments fall into the sea rather than reaching land. The problem is complicated because, in addition to the mean falling velocity, there are also larger, randomly alternating velocities caused by turbulence. (Schlichting 1979) There is a probability that some drops and salt fragments will rise even though more than half are falling. Fine dust from the Sahara (Prospero 1996) frequently reaches Britain and heavy fragments from Chernobyl went all round the world. A method, to be discussed later, may allow an *increase* in the falling velocity of residual salt so as to reduce greatly the amount of salt reaching land. Particles larger than 5 microns fall out of the upper atmosphere quite rapidly and there is a very large amount of salt already there from the spray of breaking waves. Nevertheless it seems unwise to inject anything smaller than 10 microns until we understand all the physics.

### Power levels

The well-known equation for the power output  $P$  of a wind turbine of area  $A$  in a wind speed of  $V$  is

$$P = \frac{1}{2} \rho A V^3 C_p \quad (2)$$

Where  $\rho$  is now the density of air (about 1.2) and  $C_p$  is a performance coefficient which is likely to be about 0.35 depending on how well the rotation speed is related to the wind speed.

A turbine rotor area of 1000 square meters (which would now be regarded as quite small) would produce just over 100 kilowatts in a wind speed of 8 metres per second. Allowing for losses, this would lift more than a half a cubic metre of water per second to a height of 10 metres.

If we fill the foil section with circular pipes we can get about 42% of the area for water passages. We can calculate the pipe losses using the well-known equations for wall friction and bends. The pipe losses are small for a wind speed of 6 metres per second but reach 4.4 % at a wind speed of 8 metres per second.

The surface tension of sea water is about 0.078 N/m, a little higher than that of fresh water. The power to create the enlarged area for 30 micron drops is just over 15 kilowatts for a cubic metre per second. This is provided by an extra pressure drop at the nozzle exit.

If the power is dominated by the lifting of water to the chosen release height, the volume should be proportional to the cube of wind speed. The centrifugal pressure will depend on the square of this speed minus the loss of head, which will depend on the height of the release point and pipe losses. Fortunately, the flow through a nozzle rises in proportion to the square root of pressure so we can make exit velocity closely track the best value over a range of wind speeds. This means that the nozzle area should be proportional to the square of wind speed.

We can expect that the width of a nozzle slit will have a strong effect on the diameter of the drops. This diameter has to be controlled to have the best compromise between evaporation area and salt fallout range. We will therefore have to break the exit nozzle into a number of sections so that we can control the area by adding active length.

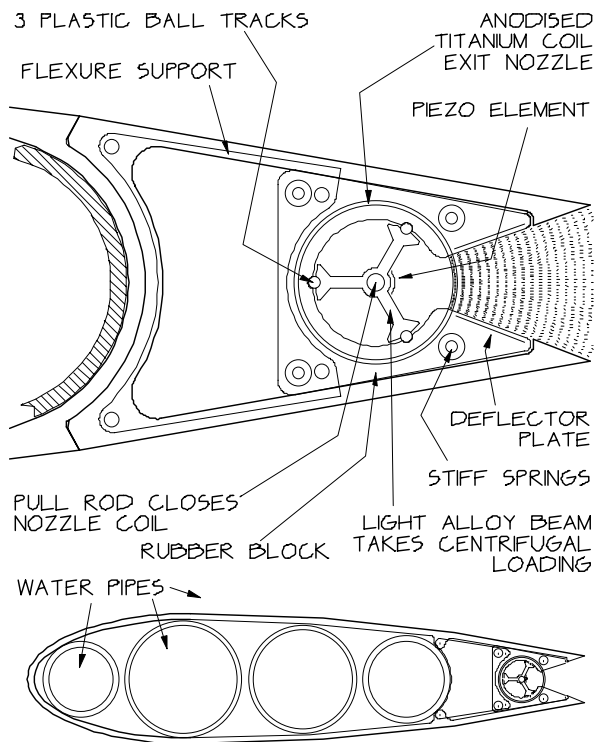
For our typical operating wind speed of 8 metres per second and a mean release height of 10 metres, the exit area is 0.015 square metres, equivalent to two round nozzles 100 mm in diameter. To get this exit area with a nominal slit width of 30 microns will take nearly 500 metres of nozzle length, every bit of which must be varied in width to an accuracy of a few microns. This presents a design problem thought initially by the author to be non-trivial, even intractable. Nevertheless a solution does exist.

### Control of drop diameter

The proposed solution makes use of the behaviour of coil-bound tension springs as shown in figure 3. If the wire of a spring is twisted as it is wound onto a mandrel, the resulting torque will tend to close the spring so that adjacent coils touch. If the coil is stretched the gaps will open to provide a long slit with the well-rounded approach path needed for an efficient nozzle. Despite this, the viscous losses through the narrow exit will contribute more to energy losses than the feed pipes.

We can make a directional exit nozzle by embedding the coil-bound spring in a block of stiff rubber and then stretching the rubber to open the gaps between coils. We can control the stiffness of the rubber by embedding further springs with smaller coil diameters wound with thicker wire. A 1.5 mm wire wound into a 110 mm coil with a 45 degree exit angle gives

the nozzle area needed. The openings of each gap will depend on the local section thickness and elastic properties of the surrounding rubber and springs. It is desirable that they should be consistent along the length of the coil. Sections of coil about a metre long can be separately adjusted to set drop diameter and flow rate so as to get the chosen tip speed ratio. The internal pressure will produce a large force tending to stretch the assembly and so control can be exercised with a central pull rod which closes the spring against the internal pressure.



**Figure 3.** A section through the exit nozzle showing the coil spring embedded in a block of rubber with four stiffening springs. Sections can be individually removed.

The short path and the very small nozzle gap means that flow will be laminar. According to Bernoulli there will be a drop in pressure as water gains velocity toward the exit. Any reduction in the slit width will reduce the local velocity, allow the local pressure to rise and so tend to restore the position of the coil. This means that we can use coils which would seem very weak springs. We can notch the wire to induce jet break up.

When we take into account all the pressure drops caused by change of height, pipes, nozzles and surface tension, the final exit pressure in an 8 metre per second wind will produce a jet velocity of about 42 metres per second relative to the blade. This is less than the 45 metres per second blade speed, leaving a net velocity relative to the ground of 3 metres per second. This loss of kinetic energy means a further loss of just under 4 kilowatts but helps to spread the spray.

Liquid sprays are used in many branches of chemical engineering and some applications demand accurate size control. Unfortunately it seems that most round nozzles designed for high flow rates produce rather a wide range of drop sizes, perhaps because flow is turbulent. This must be avoided because the larger drops will not have time to evaporate and the smaller ones will produce salt fallout. The plan is to control drop diameter by generating a high frequency (about 1MHz) ultrasonic signal from a piezo-electric element at the centre of the jet coils. Only a few kiloPascals will be needed to overcome surface tension.

### Fish filter

Engineers should always fear biology. In some areas of the sea at some times of the year the water is full of plankton which will easily clog the fine exit slit. We will have to fit large areas of filter to remove them. A convenient place would be the region between the diagonal bracing struts. Sheets of strong but inert textile like terylene with a weave slightly looser than sail cloth can be draped over supports and will form a cylindrical shape under a pressure drop. Two separate filters will allow one to be back-flushed for half the time. Material which has settled on the concave, suction side of a filter should be easier to remove when the curvature is reversed during back flushing.

Most municipal water is filtered with graded density sand beds and there is room for one in the ballast weight at the bottom of the stator shaft if we find that textile filters are too vulnerable.

Even with a good filter we must expect some material to get through. An increase in gap clearance to four times the normal value for a few seconds will clear some of the blockage. A more thorough flushing can be done as follows. All the coils connected to one of the feed pipes are closed. The pods at the bottom end of the troposkien section have rotary valves which can shut off the flow from one feed pipe and connect the coils to a downward facing dump vent. The coil gaps of just one of the exits are then opened, allowing water to fall and air to flow back into the system, sucked by the falling water. The process would be repeated for the rest of the coils on that pipe and then for other pipes.

Chlorine in quantities of one or two parts per million is very effective at stopping the growth of bio-fouling, provided that there are no gaps in supply of more than a few days. It is added in these quantities for municipal water supplies and large amounts are used for the cooling water of sea-cooled thermal power stations. We can generate it by the electrolysis of sea water or supply it as pool crystals as used for swimming baths. One 300gm pack of crystals would protect 100 cubic metres of pool water for three months. By taking a pipe and nozzle set out of use for one hour in 24 and filling it with treated water from a storage tank, we can prevent internal growth.

### Electrostatic effects

Predictions of the time available for mixing will go wrong if too many drops coalesce to form bigger ones which will fall faster. It is therefore interesting to investigate the possibility of using electrostatic repulsion. (Kraus 1991.) We often think that electrostatic forces are small but they are large compared to other forces on small drops. The spray coils would be made of a material which can be covered by a tough electrical insulator such as the hard anodic film on titanium. (We are doing initial experiments with enamelled copper wire). The metal of the coil inside the insulator would be held at a potential of, say, -300 volts relative the sea. The column of water from the sea along the pipes and into the coil will have low electrical resistance and so the water in the nozzle gap will be at nearly zero volts. However, the electrostatic field from the coil wire will attract positive charge to the water surface. If a drop of water is still in the field when it breaks away from the connection back to the sea, that charge will still be there. It will repel any other charged drop with a force depending on the product of the two charges and the inverse square of distance. The technique depends on drops separating while they are still in the field of the coil and so may depend on the success of the ultrasonic chopping described earlier.

Apart from insulation leakage no current will be drawn from the 300-volt source but, at our design wind speed of 8 metres per second, there will be a current of 24 amps for both blades. The power to charge the drops comes from extra pressure needed to eject them and is about 3.5 kilowatts.

In normal meteorological conditions there is a voltage gradient in the atmosphere of about 100 volts per metre with positive upwards. This will be grossly distorted by the production of charged drops in the space close to the turbine. But at greater distances the field will be restored. This will mean that our positively charged drops will be driven downwards. As water evaporates, charge will be left behind on the salty water. The smaller, saltier drops have less gravitational force but also lower Stokes drag. If the electrostatic force takes over from gravity they will *accelerate* downwards as they get smaller and anxieties about salt-fall are reduced. During thunderstorms the atmospheric voltage gradient reverses and gets much larger but that would not be a sensible time to add further water to the atmosphere.

### Nucleation particles

Electrostatics offers yet another bonus. Salt crystals are hydrophilic. A size of 20 microns diameter is enough for nucleation and so our salt crystals are likely to be excellent nucleation centres for triggering rain from super-saturated clouds. Relatively few are required. By changing polarity for a small fraction of the time we can produce residual salt fragments which will *rise*. This will be much cheaper and available at shorter notice than releasing silver iodide from aircraft.

Once the charged drops are moving away from the jet there is a final part for electrostatics to play. We can fit the tail of the aerofoil with "blinker plates" on each side which will act like the deflector plates of a cathode ray tube. An alternating voltage can be used to deflect the stream of drops to either side like the movement of a fish tail. This will help initial dispersion and may do some very interesting things to the aerodynamics of the rotor. A plate voltage of 3000 will deflect the exit stream by 18 degrees. Again only charging current is needed.

The author has learned, slowly and not always painlessly, that mixing electronics and water is a challenging task but, if done with sufficient attention to every detail, can be very rewarding.

### Power calculations

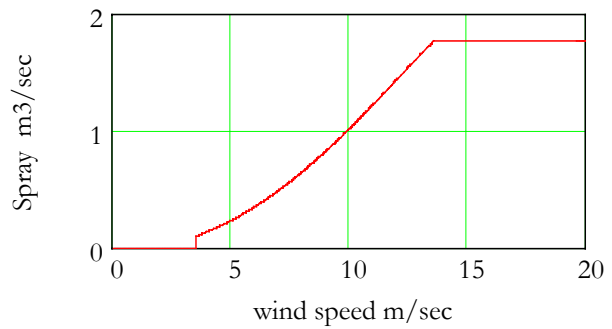
The various power consumptions for a wind speed of 8 metres per second and an effective turbine area of 1000 square metres with a performance coefficient of 0.35 are tabled below.

	Power kW	%
Power from the wind	107.5	
Lifting water for 10 metre release	67	62.3
Pipe and bend losses	4.7	4.4
Viscous nozzle losses	18	16.7
Surface tension	10.4	9.7
Electrostatics	3.6	3.3
Kinetic exit loss	3.8	3.6

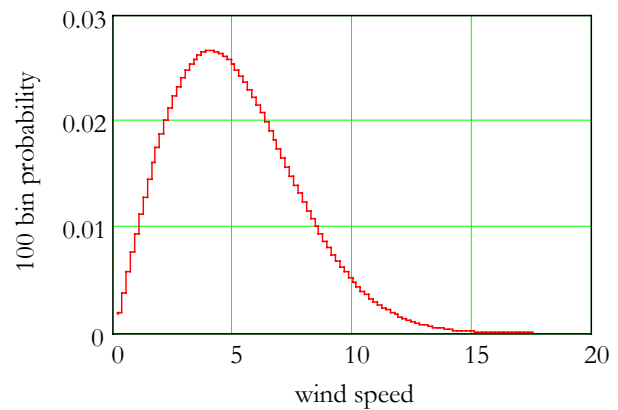
**Table I.** Power estimates for the various part of the system.

At this wind speed the output of water would be 0.67 cubic metres per second. By reducing the release height in lower wind speeds, allowing for the change in pipe losses and applying limits we can estimate productivity in terms of the volume sprayed per second as a function of wind speed in figure 4.

Meteorologists record instantaneous wind speeds and then produce monthly or annual averages. Wind turbine developers then expand the mean values using the Weibull probability distribution to calculate the chance of getting any wind speed. The percentage probability distribution for a site with a mean wind speed of 5 metres per second and a Weibull coefficient of 2 is shown in figure 5.

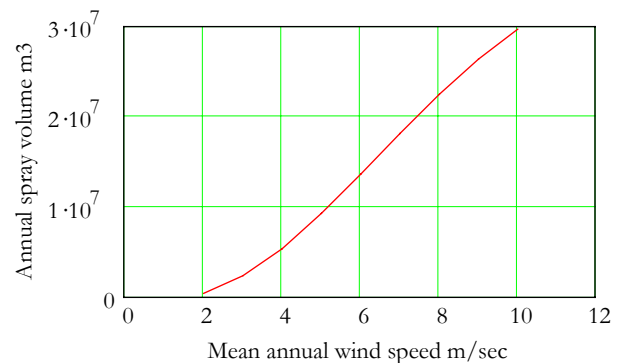


**Figure 4.** Estimates of spray volume as a function of wind speed. The lower limit is caused by insufficient centrifugal pressure. The upper is purely a conjecture based on typical cut-off limits used by the wind turbine industry.



**Figure 5.** The Weibull distribution split into 100 bins for a site with a mean wind speed of 5 metres per second, very common in the centre of the Red Sea.

Next in figure 6 we can combine data from figures 4 and 5 to show the annual sprayed volume as a function of mean wind speed for a single, 1000 square metre spray turbine.



**Figure 6.** Annual spray against mean site wind speed.

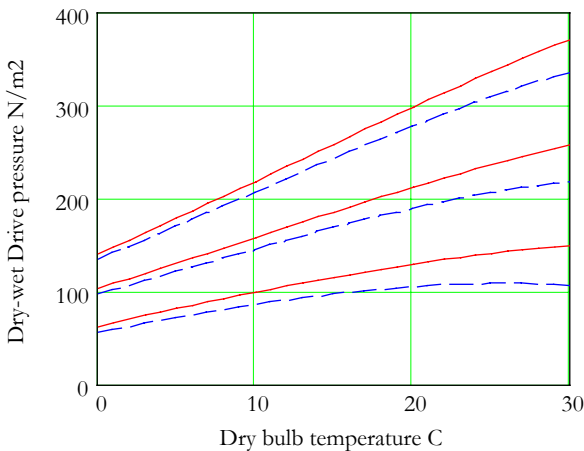
Not all of the water, perhaps only half, which has been sprayed will evaporate and not all the water which does evaporate will fall in useful places. Nevertheless it is interesting to compare these estimates with the annual flow of the river Jordan at the exit of lake Tiberias which is  $1.3 \times 10^9$  cubic metres, equivalent to 41 cubic metres per second.

## EVAPORATION

The temperature of air depends on whether it is measured with a dry or a wet instrument. The difference between the wet and dry readings is used to calculate the value of the relative humidity which is defined as the amount of water in a parcel of air divided by the amount which would have to be present for evaporation and condensation to be in equilibrium.

Measurements of wet and dry bulb temperatures and the calculated relative humidity are made regularly at all meteorological stations but usually of the air at a height convenient for the observer. The evaporation of water from a drop is driven by the difference in vapour pressure of water in the drop and water in the surrounding air. This difference can be calculated from the dry-bulb temperature and the relative humidity. The author has found only one observation (Brookes et al 1999) about the gradient of relative humidity in the first tens of metres over the sea after a wind has been blowing over a dry desert. For the centre of the Persian Gulf the value was almost zero at the top of the boundary layer.

The vapour pressure of fresh water is set by its temperature which, for a drop floating in air, will be the wet-bulb temperature of the surrounding air. This is lower than the dry-bulb temperature of the air if the relative humidity is less than 100%. The vapour pressure in a salty drop is a little lower than for fresh water and so evaporation is a little harder. The reduction can be estimated from Raoult's Law, (Glasstone 1940) which says that the vapour pressure of a solvent is directly proportional to its molar fraction relative to what is dissolved. For sea-water the reduction in vapour pressure is only 1.1%. When half has evaporated the reduction is 2.26% while at the moment of crystallisation the reduction is still only 10%.

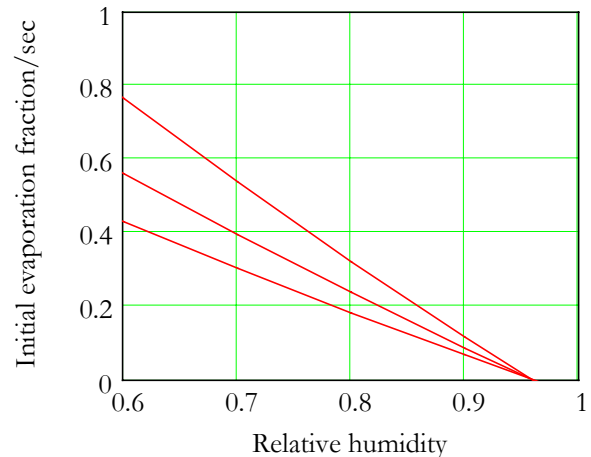


**Figure 7.** Driving pressure for evaporation at 60, 70, 80% RH.

Figure 7 shows the driving pressures of 3.5% (solid) and 7% salt (dashed) brine as a function of dry-bulb temperature for three values of relative humidity in descending order of 60%, 70% and 80%.

Having established a value for the driving pressure, we now consider the resistance to evaporation. Clearly a very large area will lower resistance. But there is also an effect from the rate at which the air containing the evaporated water diffuses away from the drop to let other drier air have access. This will depend on the velocity of the drop relative to the surrounding air and the mobility of water molecules, described by a parameter known as the diffusion coefficient. Because it takes so little force to accelerate small drops we can expect that the relative velocities between air and drops will be rather low even in the turbulent wake of a wind turbine. The difference between the use of the Stokes velocity and zero amounts to only a 10% reduction in the mass transfer coefficient.

With knowledge of pressure and resistance we can, in figure 8, plot the initial evaporation rate. The initial values are astonishingly high, (Jones 1992) many tens of kilograms a second. If the rate continued about half would be evaporated in the first second. There is nothing like an area increase of more than five orders of magnitude relative to a cubic metre of water at the sea surface to encourage evaporation. However everything combines to reduce the actual evaporation rate. The area of the drops gets smaller. The salinity is higher. Most important of all, the reduction in temperature of the surrounding air reduces the driving pressure for evaporation. The actual rate depends on how fast warm dry air can be mixed with the spray.



**Figure 8.** The misleadingly high initial rate of evaporation which will be instantly reduced by lack of latent heat. Curves are for 30, 35 and 40  $\mu$  drops in air initially at 25 C.

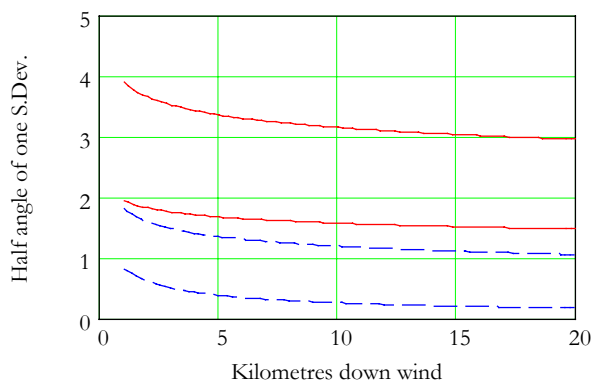
## WAKE DIVERGENCE

At the reference wind speed of 8 metres per second there will be 2700 cubic metres of air per second, weighing about 3,200 kg, blowing through the 1000 square metre rotor. If the dry bulb temperature and relative humidity are known it is possible to determine the wet bulb temperature. For example, a dry bulb temperature of 25 C and a relative humidity of 0.7 mean a wet bulb temperature of 21 C. The difference between wet and dry bulb temperatures (4 C) multiplied by the specific heat of air (1007 Joules per kilogram C) multiplied by the weight of air is the amount of heat available for the latent heat of evaporation. It comes to 12.9 M Joules. But the latent heat needed for evaporation is 2.25 M Joules per kilogram so that the air going through just the rotor could evaporate only 5.7 kg of water, far short of the 680 kg a second we are spraying. To evaporate that amount we would need all the specific heat from a window nearly 40 times the area of the rotor, otherwise evaporation will be limited by lack of latent heat. The question is therefore how fast the wake of the turbine diverges before too many of the water drops fall into the sea.

The study of plume dispersion was first applied to gas warfare but has since been used for nuclear fallout and now, intensively, for studies of air pollution. A bewildering and sometimes contradictory set of mathematical models needing experimentally measured coefficients has been suggested. At least 30 computer applications are commercially available and are described in a recent report by the European Process Safety Centre (1999).

The models suggest that the cross-sections of a neutrally buoyant plume are elliptical. The density follows a normal distribution with different standard deviations in the vertical and horizontal directions. The standard deviations grow

with distance down wind at slightly less than a linear rate by an amount which depends on the degree of atmospheric stability. Stability depends on how closely the actual change of temperature with altitude follows the adiabatic value plus a correction for wind speed. It may be convenient to describe plume divergence as the half angle subtended by the standard deviation ellipse at a distance down range back to the turbine. In figure 9 the vertical half-angle (dashed) and horizontal half angle (solid) are plotted for class D (neutral atmospheric) and class F (average stability) of the Pasquill classification for plumes over land. For class D the horizontal half-angle is a little over 3 degrees at a range of 10 kilometres. The author has been advised that this angle should apply over the sea.



**Figure 9.** Half angles of the standard deviation of a plume.

This information can be used to set distance from shore and the spacing of turbines so that their plumes overlap at about the halfway point. It also helps us decide on the smallest drop that can be released without danger of salt fallout.

The predictions are based on land observations. They take no account of an obstruction with the violence of a wind turbine, the different conditions over the sea and the effects of fast cooling from the dry bulb to the wet bulb temperature. If we want to increase the supply of latent heat for higher wind speeds and higher relative humidity we may consider ways to increase turbulence. It is pointless to lift water that cannot be evaporated and better to use some wind energy to stir the wind.

A first step would be to operate the rotor at a lower than optimum tip-speed, which would induce flow separation and vortex generation at the trailing edges. The direction of spin of the vortex for the downwind blade will be opposite to that of the upwind one. These vortices will initially be moving downwind at a third or a little less of the speed of the wind outside the rotor and so will have a substantial relative velocity. They will therefore experience the Magnus effect and behave like Flettner rotors with a sideways force to make them diverge. They will also be doing some useful centrifuging of drops.

The next technique is to give the aerofoil fairings on the lower cross arms a nose-down inclination of about 8 degrees. This will produce a down force on the rotor and a corresponding up force on the airflow to lift the droplet stream.

A third way would be to interleave spray turbines with conventional horizontal-axis, electricity generating ones. The torque in the rotor will induce an equal and opposite torque in the stream of air flowing through it, which will impose an excellent helical movement.

We might finally consider the design of a non-generating turbine designed only to disperse wakes. This might take the form of the rotor of a high-solidity horizontal-axis machine with its axis inclined at 45 degrees to combine centrifugal and uplift effects.

## Cliff spattering

There may be some sites where a combination of high, rocky slopes above valueless beaches would allow a combination of drop sizes, release heights and offshore distances such that drops of very strong brine impinged on the cliff face rather than dropping into the sea. The brine would evaporate as it trickled down, using solar heating of the rocks to provide latent heat not provided by the airflow. The water vapour would rise up the slope for rain-making. Deepening crusts of salt would be left behind. Sea salt is a valuable source of chemicals and would be periodically removed. The solar input would not exceed 1000 Watts per square metre of rock so a large area of slope would be needed.

## BRAKES

Wind turbine designers are concerned about the dangerous problem of over-speeding, and regulations for land plant require two independent brakes which must function in the absence of control power. Spray turbines have several possible mechanisms. If the water is directed to two *forward* facing jets with the same cross section as the feed pipes instead of the nozzles at the trailing edge, there will be an instantaneous retarding torque about 100 times higher than that of the normal turbine drive. The greater flow of water through the turbine will also retard the rotor because of the need for accelerating a greater mass flow in the slope pipe section.

Forward facing jets deal very effectively with over-speed caused by excess wind. However, they need water to work and over-speed could also be caused by a flow blockage from seaweed or flotsam. We can therefore fit an air brake acting at the outer ends of the cross arms and triggered by centrifugal action. Finally we could release air from a buoyancy compartment so as to lower the turbine deeper into the water and immerse high drag appendages on the slope pipes.

## MOBILITY

When the operation of machines and the salt-fall problem is well understood, arrays can be permanently moored at the right distance from land. There are, however, arguments in favour of mobility for early research units and perhaps later for larger numbers. Mobility would allow turbines to be concentrated so as to bring their output up to the critical levels needed for rain and to be redeployed elsewhere if rain is no longer required. There may be a need for seasonal changes from one side of an island or narrow seaway to another. A flotilla of machines could patrol a coastline to give planned rainy hours to places along it. A concentration of machines would help to fight bush fires such as occur frequently in the south of France.

It is difficult, expensive and often dangerous to tow one vessel by another, especially if they have widely different responses to wave action. Some form of self-propulsion could be useful. This could be achieved with conventional outboard motors clipped to the stern of the pontoons. Alternatively the problem of fuel supplies could be avoided by fitting a three-phase synchronous alternator rated at about 30 kilowatts to the inside the stator mast and driven by the rotor through epicyclic gears at about 1500 rpm. The gears could be built into the top of the generator plate and be integral with the lower bearing, an SKF Carb unit which has high tolerance for angular and axial movements.

This generator would give power on the static part of the turbine which could be used for driving back-flush pumps or for propulsion using induction motors at the stern of both pontoons. The mechanism can also contain a smaller, generator to power the controls on the moving parts of the system. This could be built as a ring in the gap between the stator and rotor.

It is possible for a wind-powered vessel to make headway even directly into the wind and to work very well on a beam reach. Marine safety authorities would, today, be alarmed at the prospect of thousands of unmanned, free-range turbines with rapidly spinning rotors drifting out of control across busy sea lanes. However one day, ships, aircraft and even passenger cars may be controlled from central computers and the idea may not look so far fetched.

## INTERACTION OF DESIGN PARAMETERS

**Wind speed** has a cube law relationship with power generation and so also with spray volume up to a safety limit. It also sets values for stability in heel and mooring force. The cube law may be modified if release height is varied,

The **tip-speed to wind speed ratio** sets the performance coefficient for a given rotor solidity. High values give good nozzle pressure. Lower tip speeds increase the angle of incidence of airflow relative to blade chord eventually leading to stall. This can be deliberately done to improve mixing in the wake. It is important to remember that a fall in performance coefficient below the theoretical Betz limit of 16/27 or 59% may indicate the presence of shed vortices that would be very useful for dispersing drops. We may evaporate more water from what would look like a very poor turbine.

**Rotor diameter** drives area and so production volume but, for a given tip speed, has no effect on exit jet pressure.

**Rotor height** also drives area and so productivity. But large heights mean more tilting moment, which has to be resisted by bigger or more widely spaced pontoons.

**Blade chord** sets solidity and the best values are known for any given tip-speed ratio.

High **aerofoil section thickness** gives strong blades, plenty of room for water pipes and a reduction in blade stall at lower tip-speed ratios. The cost of the extra drag is small.

The **slope angle** of the blades and the **radius** from the rotor axis at the point at which it breaks the water surface set the lowest rotation speed which can prime the pump.

An increase of **release height** extends the time available for evaporation but demands more pumping power so that it reduces productivity. Values between 5 and 15 metres are likely. High values will be needed in high wind speeds just to get enough nozzle area but low release heights would be useful to maintain output at low wind speeds when drops take longer to reach the land. High values of release height if coupled with larger drop diameters increase the slope of descent and so reduce salt fall.

**Nozzle area** sets the flow for a given pressure and so the torque needed to accelerate water in the sloped pipe. This allows rotor speed to stay close to the best ratio of tip-speed to wind-speed.

**Drop diameter** has an inverse relationship to evaporation area and an inverse square relationship to falling rate so that there is an inverse cube relationship to evaporation opportunity. If slit width has to be set for these reasons, nozzle area has to be adjusted by switching in more or fewer coil sets.

The **charge** on a drop helps separation and stops coalescence. It can change fall velocity either up or down according to polarity. It is a powerful way to increase the slope of descent towards the end of evaporation and, when reversed, to provide cloud seeding.

The **ultrasonic chopping frequency** and the exit velocity will affect drop diameter. If chopping can be achieved we may be able to get a very narrow spread of diameters.

**Notch pitch** can be used to assist jet separation.

**Salt fallout** is worst in high winds, high atmospheric instability and low relative humidity but can be reduced by low drop heights, large drop diameters, long distances offshore and high electrostatic charge.

## ENVIRONMENTAL IMPACTS

Gentle and reliable rain is seen as a great blessing except by those who have it and believe they have too much. Spray turbines will be deployed only where they are needed. However, all other possible effects must be considered.

The immediate effect will be an increase in the relative humidity and a drop in temperature of winds blowing from the sea unless humidity was high already. This will continue for some distance inland and will approach the wet bulb temperature of the air to seaward of the turbine array.

Lower temperature and higher relative humidity will reduce the evaporation rate of any previous rainfall. Eventually there may be a further effect from any increase in vegetation. As the treated air goes over rising ground there will be an increase in the probability of formation of cloud, mist and rain. Cloud will reflect more solar energy back into space than if it reached the ground, reduce temperatures during daytime and increase them at night. Rain will clean the air and reduce the production of dust. Precipitation will be gentle, much more like the conditions which the Irish call 'soft' rather than the torrential rains which occur rarely but violently in equatorial regions.

There will be local increase in the salinity of sea water down wind of the spray turbine. This salty water will be heavier and so will sink, giving an exchange of nutrients. This phenomenon is marked at the entrance to the Red Sea. The effect will be offset by increased flow from rivers. There are already quite large salt falls in coastal regions just from the bubbles generated by breaking waves. These can amount to 50 kilograms of salt per hectare year. Rain flowing out through rivers is the only means of removal. If drop diameter is chosen correctly and electrostatic drop charging works, this salt accumulation on land can be reversed.

In many parts of the world, ground water is being abstracted at rates which allow the ingress of salt from the sea. Extra rain will replenish aquifers, purify the ground water and prevent further ingress. Over a long period, the replenishment of ground water and a rise in the water table under deserts can have a useful effect in reducing ocean levels.

In the long term, irrigation converts fertile land into a desert by leaving behind accumulated materials left over from evaporation. This happened in biblical times to the once fertile crescent between the Tigris and the Euphrates and is happening to a dangerous extent in Israel and California today. Spray turbines will reduce the need for irrigation. Rain, sunshine and hydroponics can produce organic matter which can be added to desert sand and make it useful again.

Ship wrecks and oil platforms are known to be attractive to fish. Filters which provide surfaces of accumulated food will be even more attractive.

## RESEARCH PROGRAMME

The most important first step will be to modify a meteorological climate model to predict the effects of increasing the relative humidity of the marine boundary layer to about 95% along a wide strip of arid coastline with a variety of inland contours. All the water which evaporates will eventually have to come down somewhere but it is a very difficult meteorological question to say where this might be. If the scheme produces rain in places which already have too much we apologise and forget spray turbines. If the results in some conditions and sites look promising we would explore lower values of humidity.

While the development and tooling for a reliable, full-size anodised-titanium rubber-bonded spray-module suitable for mass production will be an expensive exercise, we can learn a great deal in the laboratory about drop size and electrostatic effects from coils made of spring steel or enamelled copper wire. Drop sizes can be measured from streak-length photographs

taken perpendicular to an intense light beam using the known Stokes velocities.

Numerical calculations of the lift and drag coefficients of aerofoils with cropped tail sections can be carried out and used to predict performance coefficients. However it would be harder to calculate the effect of water spray at various angles of divergence on the lift and drag of an aerofoil section or of the stall vortex of an aerofoil on the dispersion of spray. We should therefore test a short section of full-size blade with pumped water and a controlled coil nozzle in a wind-tunnel which can tolerate spray. It may not be easy to find such a tunnel and some insights could be obtained from a vehicle-mounted test rig.

It is necessary to search the existing literature for data on temperature, wind speed, wind direction and relative humidity over the coast and some tens of kilometres out to sea at sites likely to be of interest. If we cannot obtain information on the gradient of relative humidity over the sea beyond that from Brookes et al 1999, it will be necessary to design instruments to measure it. These could use sensors supported by kites, balloons, masts or even very long fishing rods. A recently developed sensor, the Sensiron AH31, has an accuracy of 2% RH, a resolution of 0.1% and a response time of 4 seconds. It is 10.2 by 8 by 3.5 mm in size and seems very suitable. (Hero 2001).

A difficult but informative measurement would be relative humidity very close to the sea surface. The sensors could be mounted on a floating ring with a high-frequency heave response to follow waves, deep skirts to give a calm internal moon pool and a well-faired deck to minimise disturbance of the airflow.

A biological survey of the size and population density of marine organisms at potential sites through the year will be necessary for the design of the inlet filters. Several competing designs should be life tested for a long period with pumped water before the turbine design is complete.

Most information on plume dispersal has been derived for use on land and may not apply directly to more stable conditions over the sea or the more unstable conditions of a turbine wake. Aerial photographs of the plumes from floating smoke generators, especially the angles of divergence, will allow us to refine estimates of the spray-to-air mixing rates and the amount of latent heat available for evaporation. One or more of the numerical prediction packages could be adapted. The angle of vertical spread is very important in calculations of salt fall and should be compared with the angle of descent of charged salt crystals.

This information could be used in a local computer model of the conditions in the wake of a turbine array and subsequent meteorology ashore, so that the correct choices of release height drop diameter and turbine spacing can be made for any site. If it is found that air is not being mixed fast enough we can consider the addition of turbulence-inducing appendages or even the deployment of some form of turbine whose sole function would be to promote mixing, especially horizontal mixing.

When all the sub-systems have been tested and modified, the first turbine rotor should be built *ashore* on the beach of a low headland with a wide angle of exposure to the sea. It would have a pipe connection across the beach for the water feed. It will be impossible to provide demonstrations of the performance of a single turbine convincing enough for an investor if the resulting rain is evenly spread over the whole of Asia. However, by integrating a sweep of observations of wind speed, turbulence and temperature up wind and down wind of a single machine, we can show how effective the evaporation process has been. This could be done with instruments mounted on a vehicle mast but ideally a series of fixed masts would give continuous readings.

It will also be possible to measure the amount of salt fallout by chemical analysis of water used to rinse collecting sheets placed at various points down wind. These should be compared with fallout at points to either side of the turbine caused by spray from breaking waves and the salt burden of desert regions.

It might be possible to demonstrate the effectiveness of a small group of, say, ten machines at a site where the wind blows up a narrow valley with high ground to either side and where rainfall is low but not zero. The ideal site would have two valleys, fairly close to one another with two sets of turbines disabled alternately.

The first level of proof would be photographs of cloud formations at lower levels than in the nearby control valley.

The second would be a reduction of evaporation rates measured from water pans in the target area.

The third would be long-term observations of wet and dry bulb temperatures.

The fourth would be data from rain gauges.

The fifth would be observation of a rising water table.

Finally, there would be surveys of changes in vegetation, increases in river flow and reductions in the salinity of run off.

The first experimental machines will be expensive, perhaps very expensive, and will have short working lives. However, once the technical feasibility of spraying and evaporation has been established we can concentrate on cost reduction and life extension to the point where the increase of land value and food production justify wide-scale deployment.

## CONCLUSIONS

Evaporation from the sea surface is slow because of a stagnant layer of high humidity air just above it.

A spray turbine can break through the humid layer and give a very large increase in area available for evaporation. In a wind of 8 metres per second, turbines spaced at 200 metres would generate an evaporating area equal to a sea fetch of 3600 kilometres every hour. They can work with sea breezes blowing over short fetches so that the Gulf of 'Aqaba can behave like a much wider stretch of sea.

An array of spray turbines could produce *new* rainfall in amounts comparable to that falling on fertile countries. The production of new rain, which will evaporate and fall again several times, should generate less enmity down wind than cloud seeding.

The technique requires relative humidity below 0.85 and mean annual onshore wind speeds above 4 metres per second.

A horizontal axis turbine could be built, but the vertical axis configuration allows a sloped pipe at the lower root of the blades to act as an efficient pump with no accurate machined parts, seals or exact fits. This more than overcomes the disadvantages relative to the horizontal configuration.

About 60% of the power of a turbine will go towards lifting water.

However dry the air it will never be possible to evaporate more than 90% of the sprayed water because of a salt crust on the drops. The air passing through the rotor window does not contain nearly enough specific heat to provide the latent heat of evaporation. With slow falling rates determined by Stokes drag and very large evaporation areas, the fraction that can evaporate is set mainly by the temperature and humidity of the surrounding air and the rate at which it can be mixed with the droplet stream. In most conditions it should exceed half.

Accurate control and variation of drop diameter is important for setting evaporation opportunity and residual salt fragment size. The best drop size is expected to be between 30 and 60 microns.

Very long adjustable nozzle slits can be made from coil springs embedded in rubber and stretched or compressed to change the exit gap. High frequency ultrasonic pressure generated from a piezo-electric transducer can be used to chop the exit jet so as to narrow the distribution of drop sizes.

It is necessary to prove that there will be a net reduction in the salt content of the soil in target areas and also that the transfer of salt crystals to the upper atmosphere is much lower than the large amount produced from wave spray. This requirement sets lower limits on the sizes of the drops which can be sprayed. A mechanism which gives drops a positive electrical charge can reduce the salt fall problem. It will also encourage initial drop separation. Negative charging might help nucleation.

All the water evaporated will eventually have to come down somewhere. The exact place may be uncertain but the first rising land encountered by the wake is the likely place for much of it. Mist and heavy dew will bring benefits from the reduced evaporation of previous rain.

In the long term, the replenishment of ground water under the Sahara could have a significant effect on ocean levels and reduce the very high costs of coastal defences round the world.

The major uncertainties are the gradient of relative humidity over the first few hundred metres above the sea and the mixing rate in the wake of a vertical axis turbine working at sea.

The major technical difficulties are the accurate control of droplet diameter and the prevention of jet blockage by marine organisms. Operation may not be possible in blooms of algae which occur in northern waters.

It is too early to make any reliable cost estimate but we can argue that the cost of turbines for generating electricity has now fallen to about \$1000 per kilowatt or \$300 per square metre of rotor area from a much higher figure. Spray turbines have no gears, generators, transformers, switch-gear, cables, land rent or foundations and the additional nozzle parts needed do not look impossibly expensive.

If mass production allows 1000 square metre machines to be built for \$300,000 each we could get 3,000 of them for the cost of one B2-A Stealth bomber. Even if we degrade their productivity to ensure that they produce very low levels of salt fall, a few hundred machines could produce the flow of the river Jordan and a few thousand that of the Nile.

## ACKNOWLEDGEMENT

The author is particularly grateful to Dr Colin Pritchard for his patient explanations of the evaporation process.

## REFERENCES

- Brooks, I. M., Goroch A. K. and Rogers D. P., *Observations of strong surface radar ducts over the Persian Gulf*. Journal of Applied Meteorology, 38, 9. pp 1293-1310. 1999.
- Csanady GT, *Air-Sea Interaction*. Cambridge University Press Cambridge 2001.
- European Process Safety Centre. *Atmospheric Dispersion*. Institution of Chemical Engineers. Rugby 1999. (Translation from French of a report from 1995.)
- Glasstone S. *Physical Chemistry*, Van Nostrand New York.1940.
- Hero Electronics *Technical data on Sensiron AH31*, Dunstable Street, Ampthill, Bedfordshire 2001. Sales@heroelec.co.uk.
- Jones FE. *Evaporation of Water with Emphasis on Applications and Measurements*. Lewis, Chelsea Michigan 1992.
- Kraus JD *Electromagnetics*, McGraw Hill New York 1991.
- Schlichting H. *Boundary Layer Theory*. McGraw Hill New York 1979.

Li-Jones X., Maring H.B., Prospero J.M. *Effect of relative humidity on light-scattering by mineral dust aerosol as measured in the marine boundary layer over the tropical Atlantic Ocean*. Center for Clouds, Chemistry and Climate, Scripps Institution of Oceanography, University of California, San Diego, La Jolla, CA.

Prospero, J.M. *Saharan dust transport over the North Atlantic Ocean and Mediterranean*. The Impact of Desert Dust from Northern Africa Across the Mediterranean, edited by S. Guerzoni and R. Chester, 133-151, Kluwer Academic Publishers, Dordrecht, 1996.

Reis GE., Blackwell BF, *Practical Approximations to a Troposkien by Straight-Line and Circular-Arc Segments*, SAND74-0100, March 1975.

## USEFUL WEBSITES

<http://orbit36i.nesdis.noaa.gov/atovs/movies>  
Has two month animations of world meteorological data.

<http://pm-esip.msfc.nasa.gov/>  
Visualisation and real meteorological data sets.

<http://www.cgd.ucar.edu/csm/>  
Numerical models with long term results.

<http://ag.arizona.edu/~lmlilich/top.html>  
Desert and humidity information.

<http://www.sandia.gov/wind/>  
Has many useful papers on vertical axis wind turbines.

<http://www.ifpri.org/2020/dp/dp12.htm>  
The political aspects of the water problem.